

AFR-64R

Rich Burn Air/Fuel Ratio Control System

A lot of control in a single package: The AFR-64R air/fuel ratio controller monitors ambient changes, reacts with precision and diagnoses potential problems before they become costly.

Emissions Compliance: The AFR-64R precisely tracks the air/fuel mix to maintain targeted emissions levels – regardless of variance in load, ambient air temperature or fuel composition.

Flexibility: The AFR-64R controller stores up to 64 load-specific air/fuel set points and automatically tracks engine load changes based on engine RPM and manifold air pressure.

Cost Savings: Pinpoint performance problems as soon as they occur—misfires, engine valve issues and more – to cut the costs of maintenance, downtime, labor and replacement parts.

Whether you need better emissions compliance, engine prognosis/diagnosis and trouble-free equipment life, the AFR-64R helps maximize the efficiency of the engine and its three-way catalytic converter.



Dimensions

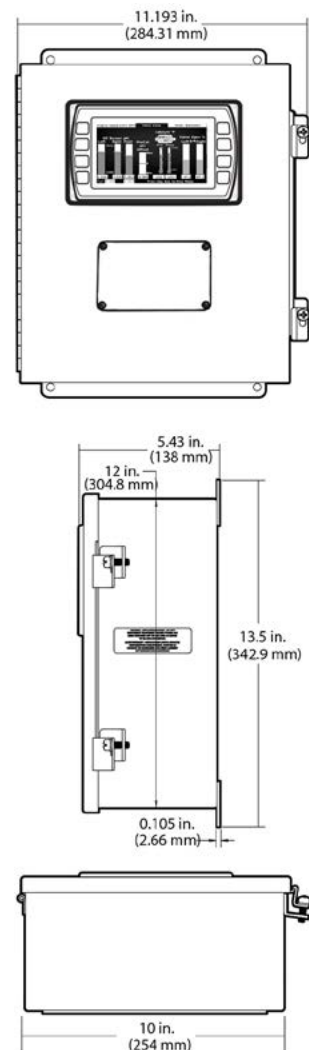

Technical Features

- Fast, easy, low-cost installation
- Fits virtually any gas-fueled, carbureted, rich-burn industrial engine – with (or without) a catalytic converter
- Windows®-based platform compatible with most computers
- Software can be installed on laptop, PC or network
- Comprehensive 38-fault diagnostics, including continuous oxygen sensor health monitoring
- Data plotting for easy, accurate troubleshooting
- Separate alarm and shut-down dry contact relays
- Pre-catalyst closed loop, exhaust oxygen feedback control
- Post-catalyst exhaust oxygen feedback; cascade control for fast, real-time adaptation to changing catalyst performance
- Variable set-point for pre-catalyst and post-catalyst exhaust oxygen control – for real-time response to varying engine loads
- Up to 64 load-specific air/fuel set points to map your engine
- Catalyst temperature monitoring for catalyst over temperature protection
- Drives up to two control banks for operation on V type engine configurations
- High-speed full-authority butterfly fuel control valves for quick response time.

Technical Features - continued

- Multiple valve control options:
 - Full Authority Valve controls all engine fuel via system- controlled butterfly valve
 - Trim Fuel Valve adds supplemental fuel to the air intake via system-controlled proportional fuel valve
- Full-color Graphic Display - optional, enclosure or remote mounted
- RS-485/MODBUS communications support (available)
- NEMA 12 enclosure without display, IP 66 enclosure with optional display
- 12 / 24 VDC Nominal

How To Order

Options listed below applies to all Air/Fuel Controllers. All configurations may not be available. Call your sales representative or FW Murphy for more information. Sample order AFR-PD-R-64R-2-1-FA50 below.

